

# HardiePanel®

## HardiePanel® Vertical Siding Product Description

HardiePanel® vertical siding is factory-primed fiber-cement vertical siding available in a variety of sizes and textures. Examples of these are shown below. Textures include smooth, stucco, Cedarmill® and Sierra 8. HardiePanel vertical siding is 7.5mm ( $\frac{5}{16}$  in) thick and is available in 4 ft x 8 ft, 4 ft x 9ft and 4 ft x 10 ft sizes. Please see your local James Hardie dealer for texture and size availability.

HardiePanel vertical siding is available as a prefinished James Hardie® product with ColorPlus® Technology. The ColorPlus coating is a factory applied, oven baked finish available on a variety of James Hardie siding and trim products. See your local dealer for availability of products, color and accessories.



**Stucco**



**Cedarmill®**



**Sierra 8**



**Smooth**



# Installation of HardiePanel® Vertical Siding

Note: James Hardie requires a minimum 3/8 in capillary break (Rainscreens, Furring, Etc.), when installing HardiePanel on a Multi-Family/Commercial project.

## GETTING STARTED

First locate the lowest point of the sheathing or sill plate, and begin installation on that wall.

- 1) Measure up from the sill plate the height of the panels at either end of the wall and snap a straight, level chalk line between the marks as a reference line. That line is for guidance in positioning the top edge of the panels. Check the reference line with a 1219mm (4 ft) level.
- 2) Starting on one end and working across the wall, measure and trim the first panel making sure that the edge falls in the middle of a stud.
- 3) Using the chalk line as a guide along the panel's top edge, carefully position the panel and secure it with suitable fasteners and fastener spacing for the particular application as noted in the CCMC Report.
- 4) As installation continues, check the vertical edge of each panel with a 1219mm (4 ft) level.

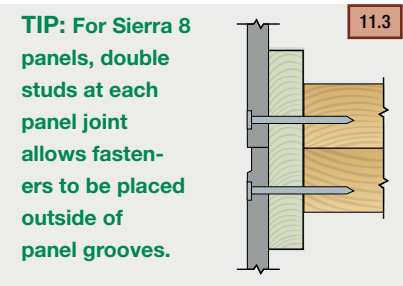
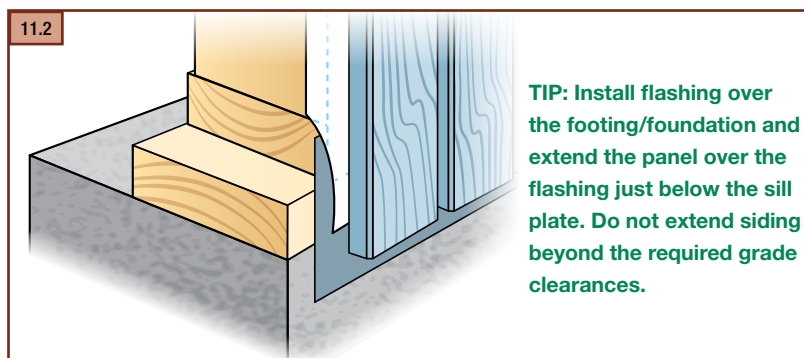
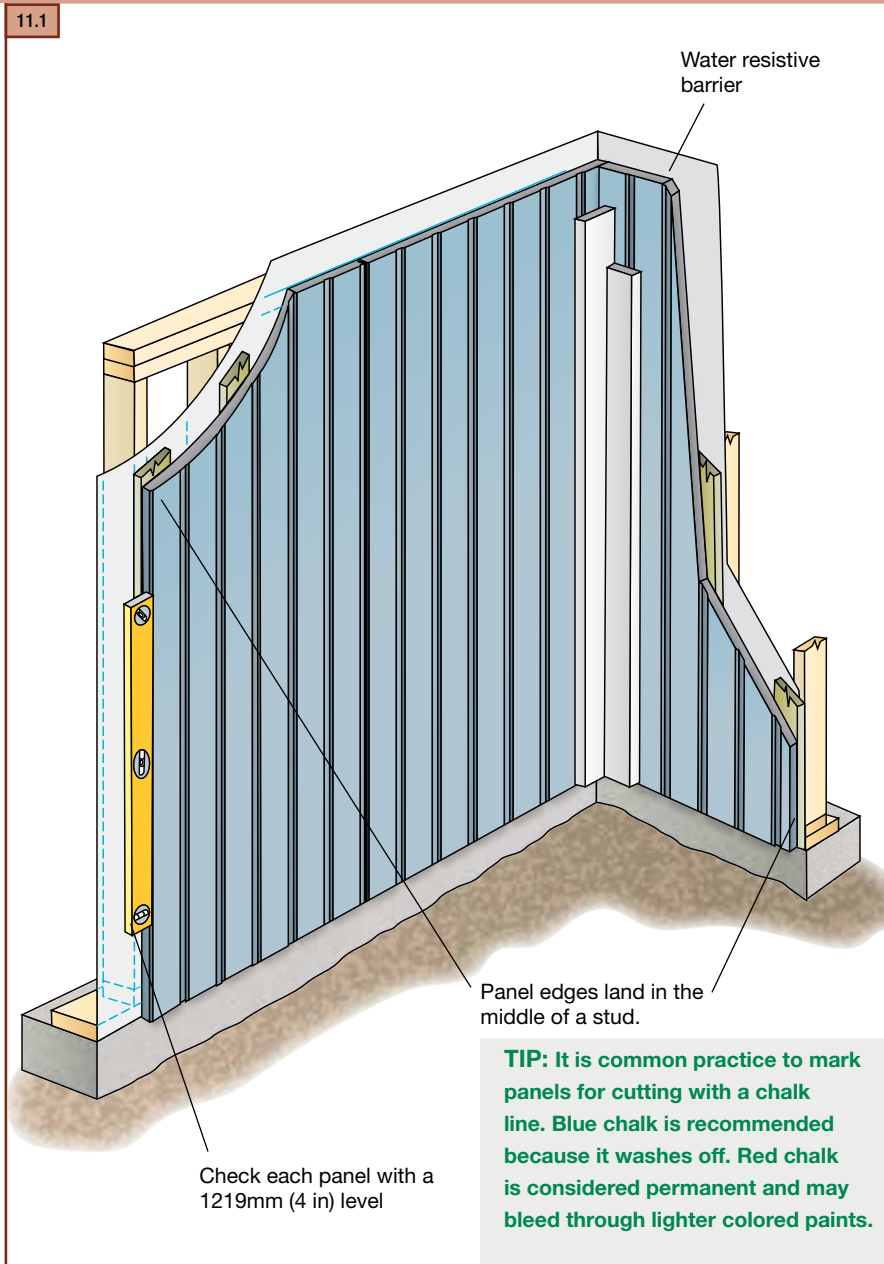

# Installation of HardiePanel® Vertical Siding (continued)

## VERTICAL JOINT TREATMENT

Treat vertical joints in HardiePanel® vertical siding by using one of the following four methods:

- 1) Install the panels in moderate contact.
- 2) Leave an appropriate gap between panels (3mm (1/8 in) is the most common), and caulk using a high-quality paintable caulk, that meets part 9.27.4 of the NBC requirements. (Not recommended for ColorPlus)

Panels may be installed first with caulk applied in the joints after installation; or as an option, after the first panel is installed, apply a bead of caulk along the panel edge. When the next panel is installed against the first, the edge embeds in the applied caulk creating a thorough seal between the edges of the panels.

**WARNING**

**The caulk joint method is not recommended for the ColorPlus® products**

**DO NOT caulk nail head when installing ColorPlus products**

- 3) Vertical joints may be covered with wood or fiber-cement batten strips. If James Hardie® siding or trim products are ripped and used as batten strips, paint or prime the cut edges. Batten strips should span the vertical joint by at least 19mm (3/4 in) on each side.
- 4) Metal or PVC “H” moldings can be used to join two sections of HardiePanel siding.

**TIP:** Stainless steel fasteners are recommended when installing James Hardie products.

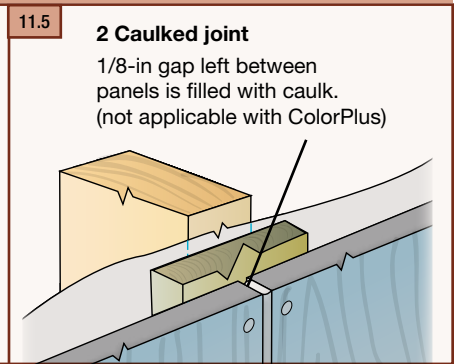
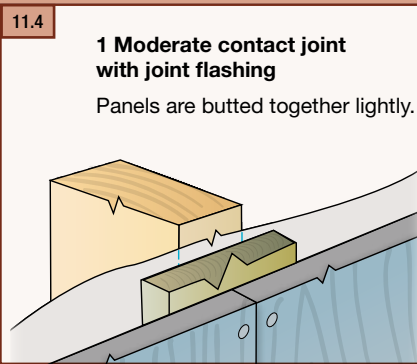

**Note:** The following outlines the recommended applications for ColorPlus and Primed panels. Not all designs will be suitable for every application:

- Exposed fasteners or battens is the recommended application for ColorPlus products
- Do not use touch-up over fastener heads for smooth ColorPlus products - primed panel recommended
- For ColorPlus panel applications that require fasteners in the field, it is acceptable to use touch-up over fasteners for Cedarmill and Stucco panel only, but correct touch-up application is important. Some colors may show touch-up when applied over fasteners. Trim is recommended to cover joints when appropriate.

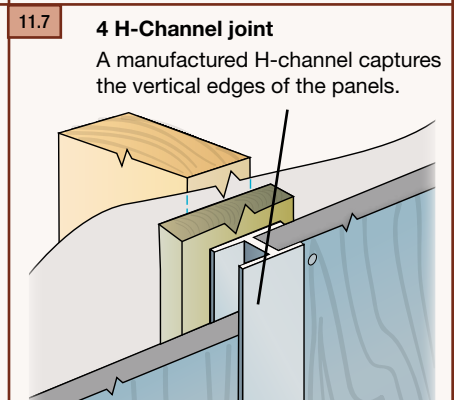
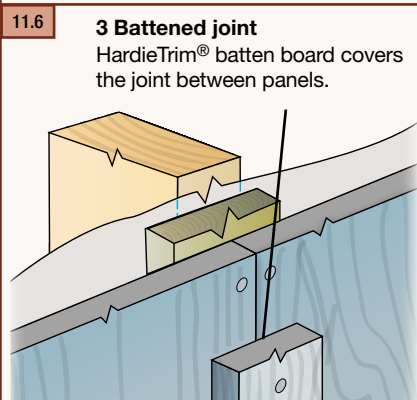

## HARDIEPANEL SIDING FASTENER SPECIFICATIONS

The Fastener Specifications table shows fastener options for a variety of different nailing substrates. Please refer to the applicable Wind load tables to determine which fastener meets your wind load

Fastening Substrate	Approved Fastener	Fastening Types
wood studs	406mm (16 in) o.c.	1 3mm x 6.8mm x 38mm (0.118 in x 0.267 in x 1.5 in) — 4d
		2 3mm x 6.8mm x 50.8mm (0.118 in x 0.267 in x 2 in) — 6d
		5 2.3mm x 5.6mm x 38.1mm (0.091 in x 0.221 in x 1.5 in) — ring shank siding nail
		9 3.1mm x 9.4mm x 31.8mm [11 GA] (0.121 x 0.371 in x 1.25 in) — roofing nail
steel studs	16 in o.c or 406mm (16 in) o.c.	7 Ribbed Bugle-Head No. 8 8.2mm x 41.3mm (0.323 in x 1.625 in) — screw
		13 2.5mm x 6.4mm x 38.1mm [AGS-100] (0.100 in x 0.25 in x 1.5 in) — ET&F
7/16 in OSB or equivalent		15 Ribbed Wafer-Head No. 8 9.5mm x 41.3mm (0.375 in x 1.625 in) — screw

General Product Information  
 Working Safely  
 Tools for Cutting and Fastening  
 General Installation Requirements  
 General Fastener Requirements  
 Finishing and Maintenance  
 HardieTrim® Boards/Battens  
 HardieSoffit® Panels  
 HardiePlank® Lap Siding  
 HardieShingle® Siding  
 HardiePanel® Vertical Siding  
 Appendix/Glossary  
 CCMC Report

## HORIZONTAL JOINT TREATMENT

In some applications such as multi-story structures or at gable ends, it may be necessary to stack HardiePanel® siding. The horizontal joints created between panels must be flashed properly to minimize water penetration. Treat horizontal panel joints by using one of the following methods:

- 1) After installing the lower course of panel siding, install vinyl or coated aluminum “Z” flashing at the top edge of the panel. Make sure that the flashing is sloped away from the wall and does not rest flat on the top edge of the panel. Install the second level or gable panels leaving a 6mm (¼ in) minimum gap between the bottom of the panel and the Z flashing. This gap should never be caulked.
- 2) As an alternative, if a horizontal band board is used at the horizontal joint, flashing must extend over the panel edge and trim attachment. Flashing for both treatments must slip behind the water-resistive barrier.

### 11.8 1 Simple horizontal joint

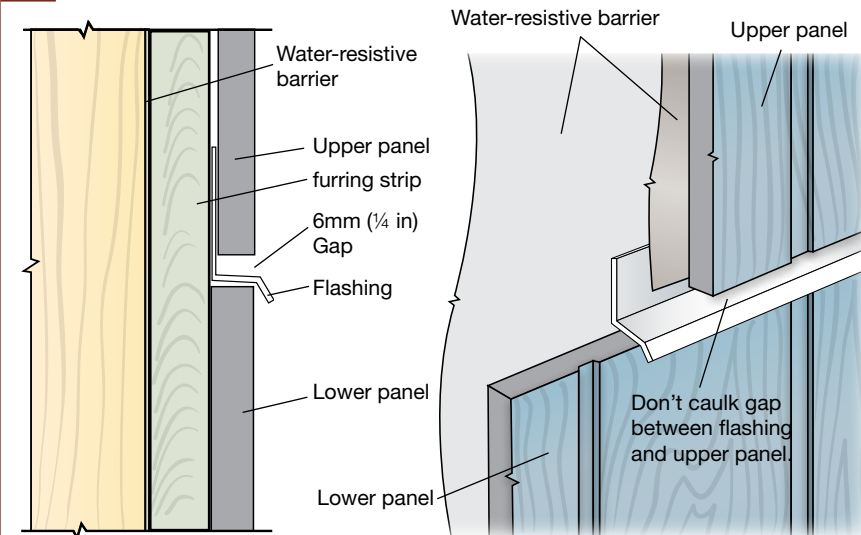

### 11.9 2 Band-board joint

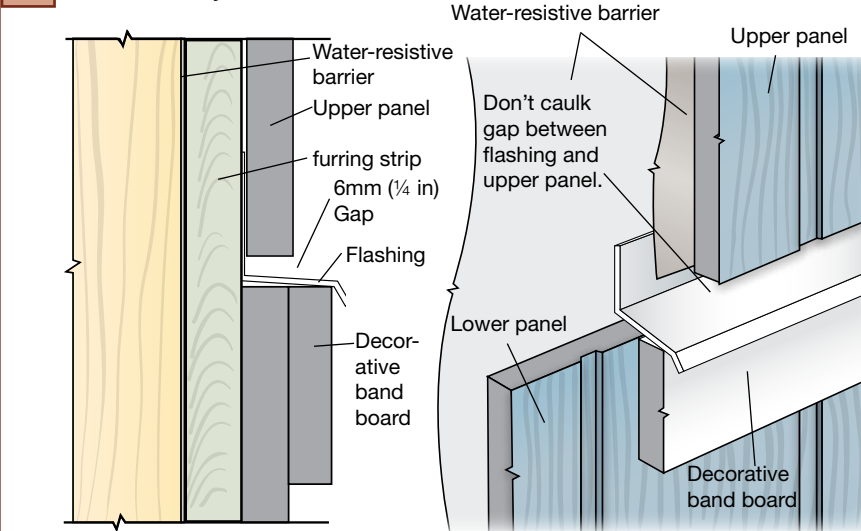

**TIP:** For best looking installation of HardiePanel Select Sierra 8 siding, carefully align vertical panel grooves at 1st to 2nd story or gable junctures.



## WARNING

Do not bridge floors with panel siding. A horizontal joint shall always be created between floors.

**TIP:** For the most symmetrical looking wall, plan the installation so that a full panel is centered on the wall or gable with equal-size panels cut for each end. As an alternative, plan the installation so that a full panel is located on either side of the wall center, again leaving equal-size panels on each end. These strategies might entail a centered framing layout. Choose the strategy that looks the best and uses material most efficiently.

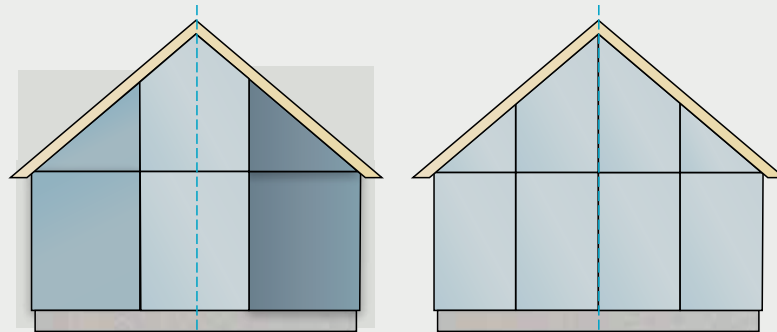



# Installation of HardiePanel® Vertical Siding (continued)

## WINDOWS, DOORS, AND OTHER WALL PENETRATIONS

In panel installations, trim is typically overlaid on top of the panel. Special attention needs to be paid to trim flashing at the tops of openings. Below is one method for properly flashing trim in a panel application:

- 1)** After installing the window, cut and install a 6mm (¼ in) thick shim above the window. The shim should be the same width as the trim, and it should be as long as the width of the window.
- 2)** Over the shim, install flashing wide enough to cover thickness of the trim and long enough to cover the trim head piece.
- 3)** Install the panel to the window and around the shim taking care not to damage the flashing and leaving a 6mm (¼ in) gap between the panel and the horizontal part of the flashing.
- 4)** Install the trim around the window, slipping the head piece under the installed flashing.

11.10

**1** Install 6mm (¼ in) thick shim over the window.

**2** Install flashing over the shim and under the water-resistive barrier.

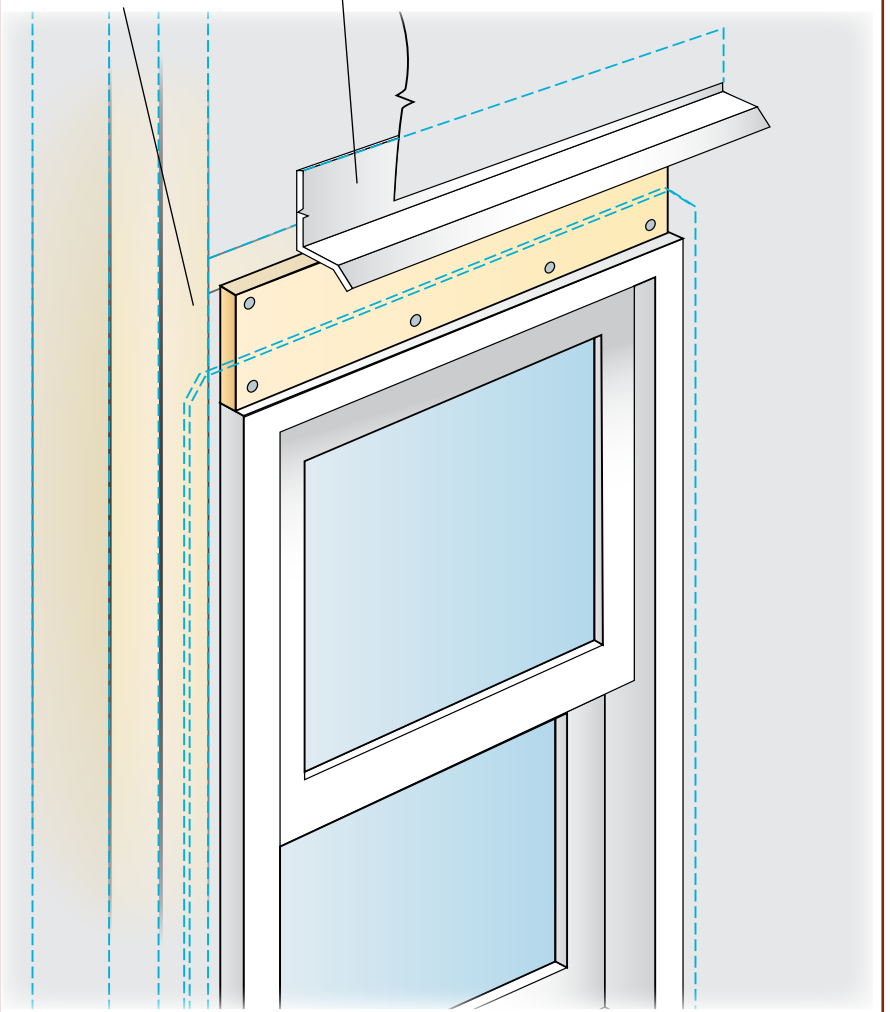

11.11

**3** Cut and fit panel around the shim and flashing. Leave 6mm (¼ in) gap between the flashing and the upper panel.

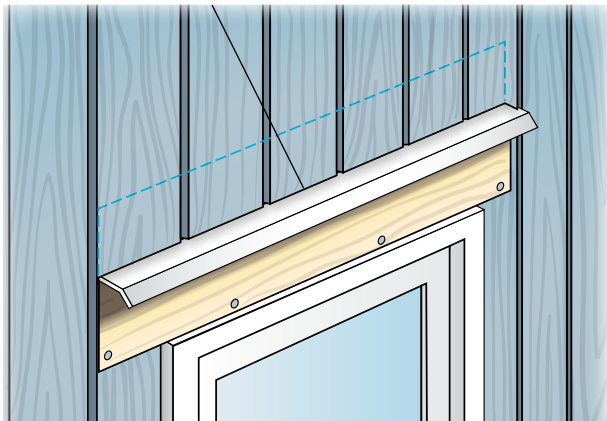

11.12

**4** Install window trim under the flashing.

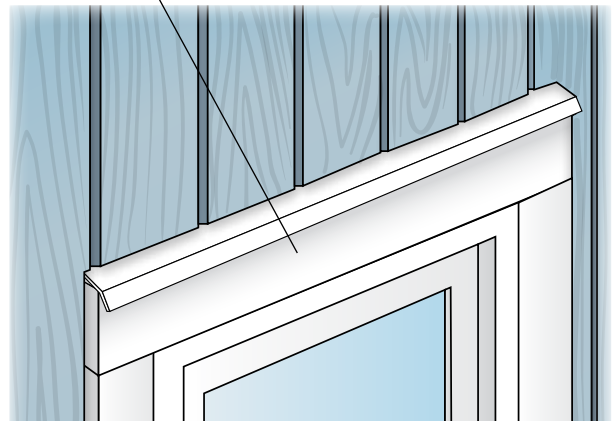

## RAIN SCREENS

### The Use of Rain Screen Systems:

James Hardie will support the use of its exterior siding products with rainscreen systems, but does not take sole responsibility for the entire wall assembly or system. James Hardie expects the designer or builder using our components as part of the rainscreen system to:

- Adhere to all the installation requirements listed in the relevant product installation instructions.
- Provide adequate details for water management.
- Make the decision about the use of rainscreen.
- James Hardie products does not recommend “drainage mats” or drainage boards” to provide the necessary capillary break behind our siding. These products can compress during the installation process, impairing the drainage channels and further causing a “wavy” appearance in the plank or panel products.
- Understand the interaction between system components and how each of the components in the system interacts.
- Design of the building envelope accounting for both interior and exterior moisture control.

### Installation Over Furring:

When reviewing the following details for attaching to wood furring or framing, an important consideration is that the fastener chosen must be fully encompassed by a wood substrate - the furring may count as all or part of the necessary penetration if it has been proven that the furring and/or wood substrate has the same or better holding power as a timber stud.

### Design responsibility

In all cases it is the sole responsibility of the architect, envelope engineer or specifier to identify moisture related risks associated with any particular building design and to make any appropriate adjustments or modifications to the installation guidelines given by manufacturers. Wall construction and design must effectively manage moisture, considering both the interior and exterior environment of the building.

### Attaching panel siding to wood furring:

When attaching panel siding products over wood furring, the typical fastener used is the 6d common 50mm (2 in) long nail. This fastener is going to be the shortest fastener approved for fastening panel siding products into wood, therefore the furring must be a minimum of 43mm (1 11/16 in) thick to achieve the same values as CCMC, given stud spacing, building height, and exposure category.

It is deemed an acceptable practice to not fasten along the top and bottom plates for the 7.5mm (5/16 in) HardiePanel® configurations listed in the CCMC using the following fastener type:

- 2.3mm (0.091 in) shank X 5.7mm (0.225 in) HD X 38mm (1.5 in) long - ring shank nail
- 6d common 50mm (2 in) long - nail
- Min. No. 8 X 0.311 HD X 1 in - ribbed bugle head screw
- 2.5mm (0.10 in) X 6.4mm (0.25 in) HD X 38.1mm (1.5 in) long - ET&F pin or equivalent

Conditions of use:

- This practice is acceptable for transverse load only.
- This practice is not acceptable for racking shear values or in-plane forces other than perpendicular/normal wind forces.
- All vertical joints shall occur over framing.
- All other James Hardie Installation Requirements shall be followed.

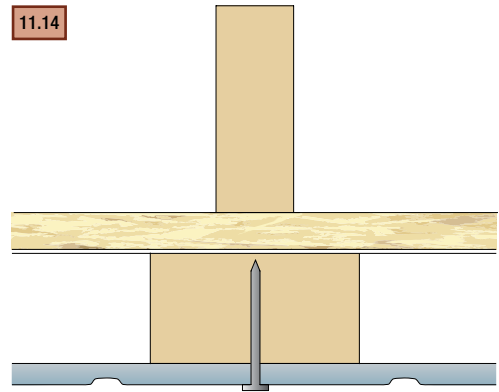
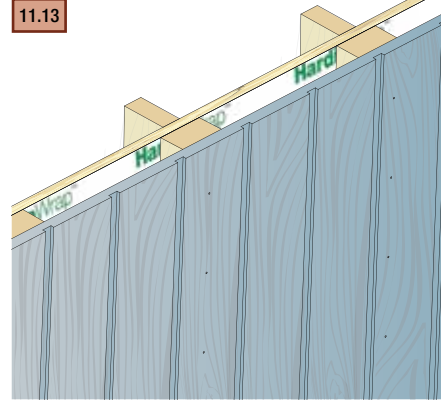

# Installation of HardiePanel® Vertical Siding (continued)

## RAIN SCREENS

### Attaching panel siding to steel furring:

When attaching panel siding products to metal furring, the steel furring must be a minimum 20 gauge steel. A fastener should be chosen out of the CCMC, which is approved for attaching to steel framing. Two general rules that should be considered when choosing a fastener is that a nail (pin) must penetrate steel furring 6mm (¼ in), and screws must penetrate steel furring 3 full threads. Therefore, if the rules for steel fastening are followed – given stud spacing, building height, and exposure category – the values are the same as CCMC states for the chosen fastener.

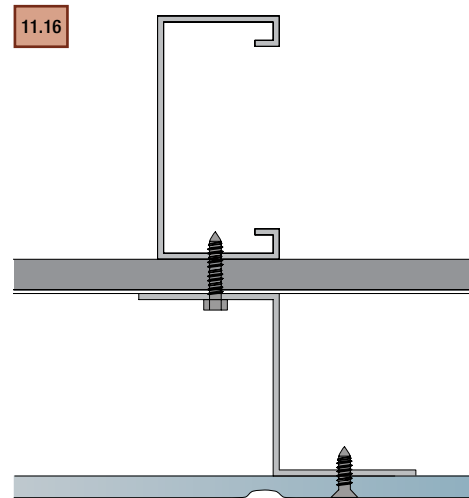
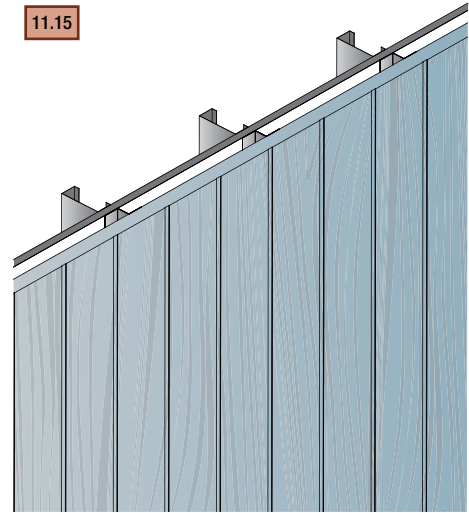

# HardiePanel<sup>®</sup> **HL5** Vertical Siding



EFFECTIVE FEBRUARY 2014

Visit [www.jameshardie.com](http://www.jameshardie.com) for the most recent version.

INSTALLATION REQUIREMENTS RESIDENTIAL SINGLE FAMILY ONLY - PRIMED & COLORPLUS<sup>®</sup> PRODUCTS

## SMOOTH ▪ CEDARMILL<sup>®</sup> ▪ SELECT SIERRA 8 ▪ STUCCO

**IMPORTANT: FAILURE TO INSTALL AND FINISH THIS PRODUCT IN ACCORDANCE WITH APPLICABLE BUILDING CODES AND JAMES HARDIE WRITTEN APPLICATION INSTRUCTIONS MAY LEAD TO PERSONAL INJURY, AFFECT SYSTEM PERFORMANCE, VIOLATE LOCAL BUILDING CODES, AND VOID THE PRODUCT ONLY WARRANTY. BEFORE INSTALLATION, CONFIRM THAT YOU ARE USING THE CORRECT HARDIEZONE INSTRUCTIONS. TO DETERMINE WHICH HARDIEZONE APPLIES TO YOUR LOCATION, VISIT [WWW.HARDIEZONE.COM](http://WWW.HARDIEZONE.COM) OR CALL 1-866-942-7343 (866 9HARDIE)**

### STORAGE & HANDLING:

Store flat and keep dry and covered prior to installation. Installing product wet or saturated may result in shrinkage at butt joints. Carry product on edge. Protect edges and corners from breakage. James Hardie is not responsible for damage caused by improper storage and handling of the product.

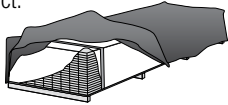

### CUTTING INSTRUCTIONS

#### OUTDOORS

1. Position cutting station so that wind will blow dust away from user and others in working area.
2. Use one of the following methods:
  - a. Best: i. Shears (manual, electric or pneumatic)
  - b. Better: i. Dust reducing circular saw equipped with a HardieBlade<sup>®</sup> saw blade and HEPA vacuum extraction
  - c. Good: i. Dust reducing circular saw with a HardieBlade saw blade (only use for low to moderate cutting)

#### INDOORS

1. Cut only using shears (manual, electric or pneumatic).
2. Position cutting station in well-ventilated area

- NEVER use a power saw indoors
- NEVER use a circular saw blade that does not carry the HardieBlade saw blade trademark
- NEVER dry sweep - Use wet suppression or HEPA Vacuum

Important Note: For maximum protection (lowest respirable dust production), James Hardie recommends always using "Best"-level cutting methods where feasible.

NIOSH-approved respirators can be used in conjunction with above cutting practices to further reduce dust exposures. Additional exposure information is available at [www.jameshardie.com](http://www.jameshardie.com) to help you determine the most appropriate cutting method for your job requirements. If concern still exists about exposure levels or you do not comply with the above practices, you should always consult a qualified industrial hygienist or contact James Hardie for further information. SD083105

### GENERAL REQUIREMENTS:

- These instructions to be used for single family installations only. For Commercial / Multi-Family installation requirements go to [www.JamesHardieCommercial.com](http://www.JamesHardieCommercial.com)
- References to the 2005 National Building Code (NBC) of Canada are made throughout this document. Local building code requirements may supersede the NBC in some locations.
- Where local building code requires a capillary break (Rainscreens, Furring, Etc.), fastener specifications per the CCMC can still be used as long as the required fastener penetration is achieved into an approved nailable substrate.
- HardiePanel siding can be installed over furring strips (in accordance with local building code requirements). HardiePanel vertical siding can be installed over braced wood or steel studs spaced a maximum of 610mm (24") o.c. Irregularities in framing and sheathing can mirror through the finished application. Refer to the table on page 3 of this document and 'Fastener Requirements' for specific arrangement and type of fasteners for your application.
- HardiePanel vertical siding can also be installed over foam insulation/sheathing up to 25mm (1") thick. When using foam insulation/sheathing, avoid over-driving nails (fasteners), which can result in dimpling of the siding due to the compressible nature of the foam insulation/sheathing. Extra caution is necessary if power-driven nails (fasteners) are used for attaching siding over foam insulation/sheathing.
- A water-resistant barrier is required in accordance with Part 9.27.3.2 of the NBC. The water-resistant barrier must be appropriately installed with penetration and junction flashings in accordance with Part 9.27.3 of the NBC. James Hardie will assume no responsibility for water infiltration.
- When installing James Hardie products all clearance details in figs. 3, 5, 6, 7, 8, 9, 10 & 11 must be followed.
- Adjacent finished grade must slope away from the building in accordance with local building codes.
- Do not install James Hardie products, such that they may remain in contact with standing water.
- HardiePanel vertical siding may be installed on vertical wall applications only.
- DO NOT use HardiePanel vertical siding in Fascia or Trim applications.
- Some application are not suitable for ColorPlus. Refer to ColorPlus section page 4.
- DO NOT use stain on James Hardie<sup>®</sup> products.
- For larger projects, including commercial and multi-family projects, where the span of the wall is significant in length, the designer and/or architect should take into consideration the coefficient of thermal expansion and moisture movement of the product in their design. These values can be found in the Technical Bulletin #8 "Expansion Characteristics" at [www.JamesHardie.com](http://www.JamesHardie.com).

### INSTALLATION:

#### Fastener Requirements

Position fasteners 9.5mm (3/8") from panel edges and no closer than 50mm (2") away from corners. Do not nail into corners.

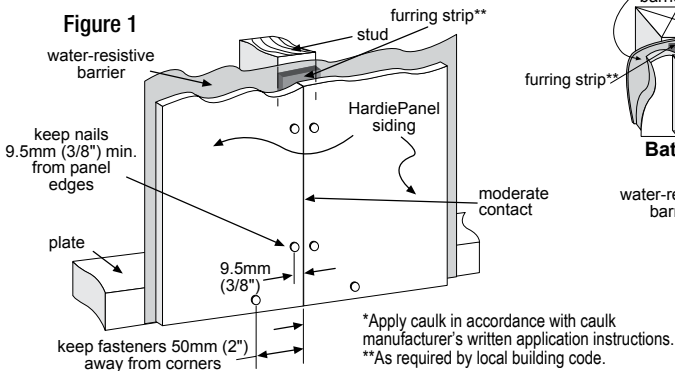

#### HardiePanel Vertical Siding Installation

- Framing must be provided at horizontal and vertical edges for nailing.
- HardiePanel vertical siding must be joined on stud.
- Double stud may be required to maintain minimum edge nailing distances.

Figure 2

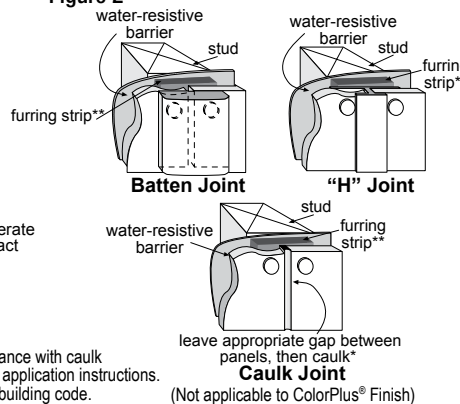

#### Joint Treatment

- Vertical Joints - Install panels in moderate contact (fig. 1), alternatively joints may also be covered with battens, PVC or metal jointers or caulked (Not applicable to ColorPlus<sup>®</sup> Finish) (fig. 2).
- Horizontal Joints - Provide Z-flashing at all horizontal joints (fig. 3).

Figure 3

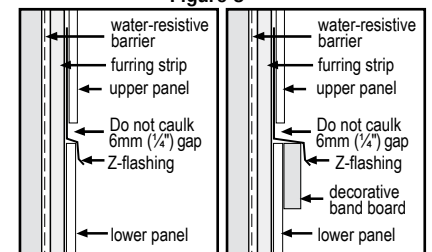
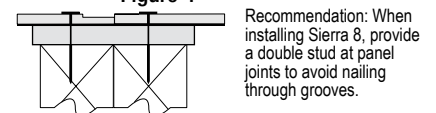

Figure 4



### WARNING: AVOID BREATHING SILICA DUST

James Hardie<sup>®</sup> products contain respirable crystalline silica, which is known to the State of California to cause cancer and is considered by IARC and NIOSH to be a cause of cancer from some occupational sources. Breathing excessive amounts of respirable silica dust can also cause a disabling and potentially fatal lung disease called silicosis, and has been linked with other diseases. Some studies suggest smoking may increase these risks. During installation or handling: (1) work in outdoor areas with ample ventilation; (2) use fiber cement shears for cutting or, where not feasible, use a HardieBlade<sup>®</sup> saw blade and dust-reducing circular saw attached to a HEPA vacuum; (3) warn others in the immediate area; (4) wear a properly-fitted, NIOSH-approved dust mask or respirator (e.g. N-95) in accordance with applicable government regulations and manufacturer instructions to further limit respirable silica exposures. During clean-up, use HEPA vacuums or wet cleanup methods - never dry sweep. For further information, refer to our installation instructions and Material Safety Data Sheet available at [www.jameshardie.com](http://www.jameshardie.com) or by calling 1-800-9HARDIE (1-800-942-7343). FAILURE TO ADHERE TO OUR WARNINGS, MSDS, AND INSTALLATION INSTRUCTIONS MAY LEAD TO SERIOUS PERSONAL INJURY OR DEATH. SD050965



## CLEARANCES

Install siding and trim products in compliance of Part 9.27.2.4 of the NBC which requires a minimum 200mm (8") for clearance between the bottom edge of the siding and the adjacent finished grade.

Maintain a minimum 50mm (2") clearance between James Hardie® products and paths, steps and driveways.

Maintain a minimum 50mm (2") clearance between James Hardie products and decking material.

At the juncture of the roof and vertical surfaces, flashing and counterflashing shall be installed per the roofing manufacturer's instructions. Part 9.27.2.4 requires a minimum 50mm (2") clearance between the roofing and the bottom edge of the siding and trim.

Maintain a 6mm (1/4") clearance between the bottom of James Hardie products and horizontal flashing. Do not caulk gap. (refer to figure 3 on page 1)

Maintain a minimum 25mm (1") gap between gutter end caps and siding & trim.

Figure 5

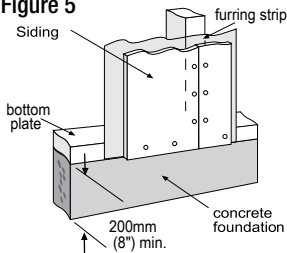

Figure 6

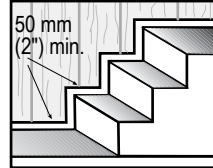

Figure 7

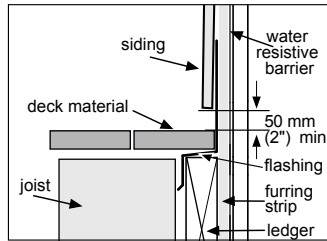

Figure 8

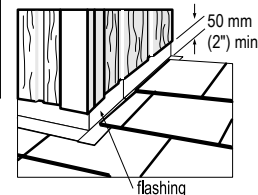
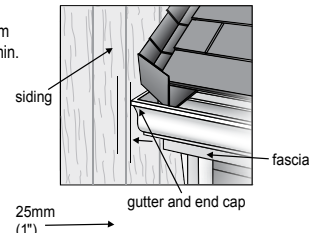
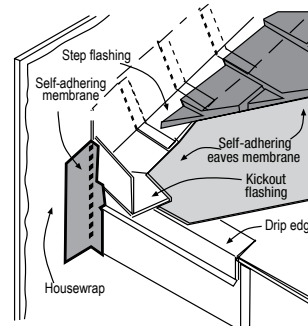
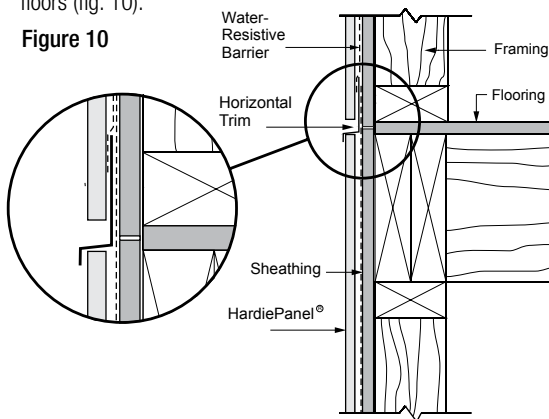

Figure 9



Do not bridge floors with HardiePanel® siding. Horizontal joints should always be created between floors (fig. 10).

Figure 10



## KICKOUT FLASHING

Because of the volume of water that can pour down a sloped roof, one of the most critical flashing details occurs where a roof intersects a sidewall. The roof must be flashed with step flashing. Where the roof terminates, install a kickout to deflect water away from the siding. It is best to install a self-adhering membrane on the wall before the subs fascia and trim boards are nailed in place, and then come back to install the kickout.

**Figure 11, Kickout Flashing \*** To prevent water from dumping behind the siding and the end of the roof intersection, install a "kickout" as required by IRC code R905.2.8.3 : "...flashing shall be a min. of 4" high and 4" wide." James Hardie recommends the kickout be angled between 100° - 110° to maximize water deflection

## BLOCKED PENETRATIONS

Penetrations such as hose bibs and holes 1 1/2" or larger such as dryer vents shall have a block of trim around point of penetration.

## GENERAL FASTENING REQUIREMENTS

Fasteners must be corrosion resistant, galvanized, or stainless steel. Electro-galvanized are acceptable but may exhibit premature corrosion. James Hardie recommends the use of quality, hot-dipped galvanized nails. James Hardie is not responsible for the corrosion resistance of fasteners. Stainless steel fasteners are recommended when installing James Hardie products near the ocean, large bodies of water, or in very humid climates.

- Consult applicable code compliance report for correct fastener type and placement to achieve specific design wind loads.
- NOTE: Published wind loads may not be applicable to all areas where Local Building Codes have specific jurisdiction. Consult James Hardie Technical Services if you are unsure of applicable compliance documentation.
- Drive fasteners perpendicular to siding and framing.
- Fastener heads should fit snug against siding (no air space). (fig. A)
- Do not over-drive nail heads or drive nails at an angle.
- If nail is countersunk, fill nail hole and add a nail. (fig. B)
- For wood framing, under driven nails should be hit flush to the plank with a hammer (for steel framing, remove and replace nail).
- NOTE: Whenever a structural member is present, HardiePlank should be fastened with even spacing to the structural member. The tables allowing direct to OSB or plywood should only be used when traditional framing is not available.
- **Do not use aluminum fasteners, staples, or clipped head nails.**

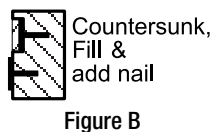
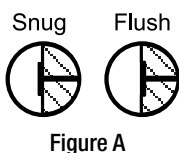

## PNEUMATIC FASTENING

James Hardie products can be hand nailed or fastened with a pneumatic tool. Pneumatic fastening is highly recommended. Set air pressure so that the fastener is driven snug with the surface of the siding. A flush mount attachment on the pneumatic tool is recommended. This will help control the depth the nail is driven. If setting the nail depth proves difficult, choose a setting that under drives the nail. (Drive under driven nails snug with a smooth faced hammer - Does not apply for installation to steel framing).

## CUT EDGE TREATMENT

Caulk, paint or prime all field cut edges. James Hardie touch-up kits are required to touch-up ColorPlus products.

## CAULKING

Elastomeric Joint Sealant is required in accordance with Part 9.27.4 of the NBC, complying with ASTM C920 Grade NS, Class 25 or higher or a Latex Joint Sealant complying with ASTM C834. Caulking/Sealant must be applied in accordance with the caulking/sealant manufacturer's written instructions.

**Note: OSI Quad as well as some other caulking manufacturers DO NOT allow tooling. DO NOT caulk nail heads when using ColorPlus products, refer to the ColorPlus touch-up section.**

## PAINTING

DO NOT use stain on James Hardie® products. James Hardie products must be painted within 180 days for primed product and 90 days for unprimed. 100% acrylic topcoats are recommended. Do not paint when wet. For application rates refer to paint manufacturers specifications. Back-rolling is recommended if the siding is sprayed. DO NOT caulk nail heads when using ColorPlus products, refer to the ColorPlus touch-up section.

**COMPLIANCE:**

HardiePanel® vertical siding complies with ASTM Specification C1186 (Grade II, Type A) and ISO Standard 8336 (Category 3, Type A).

When tested in accordance with CAN/ULC-S102, the product is recognized to have the following properties:  
 Flame Spread Rating: 0, Smoke Developed Classification: 0.

When tested in accordance with CAN/ULC-S114, the product is recognized as noncombustible.

**RECOGNITION:**

HardiePanel vertical siding may be recognized as an alternative to exterior wall cladding in section 9.27 of the NBC. For technical assistance, call 1-800-9-HARDIE.

**FIRE-RESISTIVE CONSTRUCTION:**

HardiePanel vertical siding is recognized as a component in 1-hour fire-related wall construction. Details of this assembly (Design No. JH/WA 60-01, JH/WA 60-09 and JH/WA 60-10) may be found at: [www.Intertek-ETLSemko.com](http://www.Intertek-ETLSemko.com)

**ALLOWABLE LOADS FOR STRUCTURAL EXTERIOR HARDIEPANEL® VERTICAL SIDING**

PRODUCT THICKNESS	FASTENER TYPE	FASTENER SPACING	FRAME TYPES	MAXIMUM STUD SPACING	SHEAR VALUE		ULTIMATE LOAD@FAILURE	
					(kNm)	(plf)	(kPa)	(psf)
7.5mm (5/16")	2.3mm shank x 5.7mm HD 38mm (1 1/2") ring shank nail	102mm (4") - edge/ 203mm (8") - field	Nominal 2 x 4 wood 2	406mm (16")	2.92	200	4.30	90
7.5mm (5/16")	2.8mm shank x 6.7mm HD 50mm (2") long nail	150mm (6") - edge/ 305mm (12") - field	Nominal 2 x 4 wood 1	406mm (16")	2.29	157	4.26	89
7.5mm (5/16")	2.8mm shank x 6.7mm HD 50mm (2") long nail	150mm (6") - edge/ 150mm (6") - field	Nominal 2 x 4 wood 1	406mm (16")	2.92	200	7.13	149
7.5mm (5/16")	2.8mm shank x 6.7mm HD 50mm (2") long nail	102mm (4") - edge/ 102mm (4") - field	Nominal 2 x 4 wood 1	406mm (16")	3.25	223	12.30	236
7.5mm (5/16")	2.8mm shank x 6.7mm HD 50mm (2") long nail	150mm (6") - edge/ 305mm (12") - field	Nominal 2 x 4 wood 1	610mm (24")	2.12	146	2.82	59
7.5mm (5/16")	2.8mm shank x 6.7mm HD 50mm (2") long nail	150mm (6") - edge/ 150mm (6") - field	Nominal 2 x 4 wood 1	610mm (24")	2.23	153	4.5	94
7.5mm (5/16")	2.8mm shank x 6.7mm HD 50mm (2") long nail	102mm (4") - edge/ 102mm (4") - field	Nominal 2 x 4 wood 1	610mm (24")	2.23	153	4.85	143
7.5mm (5/16")	Min No. 8-18 x 8.2mm HD x 25mm (1") long Hi-Lo S or S-12 ribbed bugle screws	150mm (6") - edge/ 150mm (6") - field	Min. No 20 ga. x 92 mm x 35 mm metal C-stud	406mm (16")	2.33	160	8.14	170
7.5mm (5/16")	2.5mm shank x 6.2mm HD x 38mm (1 1/2") long ET & F pin fastener	102mm (4") - edge/ 203mm (8") - field	Min. No 20 ga. x 92 mm x 35 mm metal C-stud	406mm (16")	2.25	154	8.14	170
7.5mm (5/16")	2.5mm shank x 6.2mm HD x 38mm (1 1/2") long ET & F pin fastener	102mm (4") - edge/ 203mm (8") - field	Min. No 20 ga. x 92 mm x 35 mm metal C-stud	610mm (24")	1.94	133	4.84	101

WIND LOAD TABLE FOOT NOTES:

1. Values are for species of wood having a specific gravity of 0.42 or greater.
2. Values are for species of wood having a specific gravity of 0.36 or greater.

**METRIC TO IMPERIAL CONVERSION TABLE**

The following table provides a conversion of the nominal metric measurements presented in these installation instructions to nominal Imperial fraction measurement values

mm	inches	mm	inches	mm	inches	mm	inches
2.3	3/32	6.7	17/64	25	1	150	6
2.5	3/32	7.5	5/16	38	1-1/2	203	8
2.8	7/64	8.2	21/64	50	2	305	12
5.7	7/32	9	23/64	92	3-5/8	406	16
6.2	1/4	12	15/32	102	4	610	24

## COLORPLUS® TECHNOLOGY CAULKING, TOUCH-UP & LAMINATE

- Care should be taken when handling and cutting James Hardie® ColorPlus® products. During installation use a wet soft cloth or soft brush to gently wipe off any residue or construction dust left on the product, then rinse with a garden hose.
- Touch up nicks, scrapes and nail heads using the ColorPlus® Technology touch-up applicator. Touch-up should be used sparingly. If large areas require touch-up, replace the damaged area with new HardiePanel® siding with ColorPlus Technology.
- Laminate sheet must be removed immediately after installation of each course.
- Terminate non-factory cut edges into trim where possible, and caulk. Color matched caulks are available from your ColorPlus® product dealer.
- Treat all other non-factory cut edges using the ColorPlus Technology edge coaters, available from your ColorPlus product dealer.

**Note:** James Hardie does not warrant the usage of third party touch-up or paints used as touch-up on James Hardie ColorPlus products.

Problems with appearance or performance arising from use of third party touch-up paints or paints used as touch-up that are not James Hardie touch-up, will not be covered under the James Hardie ColorPlus Limited Finish Warranty.

The following outlines the recommended applications for ColorPlus and Primed panels. Not all designs will be suitable for every application:

- Exposed fasteners or battens is the recommended application for ColorPlus panel products
- Do not use touch-up over fastener heads for smooth ColorPlus products - primed panel recommended
- For ColorPlus panel applications that require fasteners in the field, it is acceptable to use touch-up over fasteners for Cedarmill and Stucco panel only, but correct touch-up application is important. Some colors may show touch-up when applied over fasteners. Trim is recommended to cover joints when appropriate.

## PAINTING JAMES HARDIE® SIDING AND TRIM PRODUCTS WITH COLORPLUS® TECHNOLOGY

When repainting ColorPlus products, James Hardie recommends the following regarding surface preparation and topcoat application:

- Ensure the surface is clean, dry, and free of any dust, dirt, or mildew
- Repriming is normally not necessary
- 100% acrylic topcoats are recommended
- DO NOT use stain or oil/alkyd base paints on James Hardie® products
- Apply finish coat in accordance with paint manufacturers written instructions regarding coverage, application methods, and application temperature

RECOGNITION: In accordance with ICC-ES Evaluation Report ESR-1844, HardiePanel® vertical siding is recognized as a suitable alternate to that specified in: the 2006, 2009, & 2012 International Residential Code for One- and Two-Family Dwellings and the 2006, 2009, & 2012 International Building Code. HardiePanel vertical siding is also recognized for application in the following: City of Los Angeles Research Report No. 24862, State of Florida listing FL#889, Dade County, Florida NOA No. 02-0729.02, U.S. Dept. of HUD Materials Release 1263c, Texas Department of Insurance Product Evaluation EC-23, City of New York MEA 223-93-M, and California DSA PA-019. These documents should also be consulted for additional information concerning the suitability of this product for specific applications.

© 2014 James Hardie Building Products. All rights reserved. TM, SM, and ® denote trademarks or registered trademarks of James Hardie Technology Limited. The  and HardiePanel logo are registered trademarks of James Hardie Technology Limited.

Additional Installation Information, Warranties, and Warnings are available at [www.jameshardie.com](http://www.jameshardie.com)

